



# CHANNEL LAGGING



## CHANNEL LAGGING PANELS

---

JENNMAR's channel lagging is designed specifically to handle the ground conditions, backfill and mining equipment pressures.

The channel sections are specifically designed for use with structural members and ease of installation. The sections and materials used is design for efficient installation and transportation to the tunnel location.

A variety of sections, thickness and coating are available for project specific designs and applications.

## ADVANTAGES

---

- Provides sufficient flexural strength and acceptable cushioning effect
- Easy material handling and installation
- Corrosion resistant
- Cost effective

# CHANNEL LAGGING PANELS

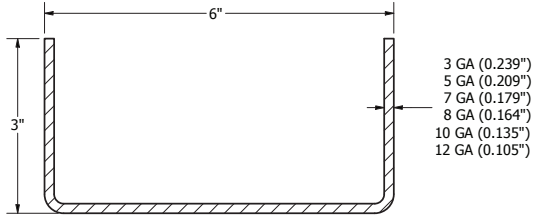

SECTION A-A

ISO VIEW

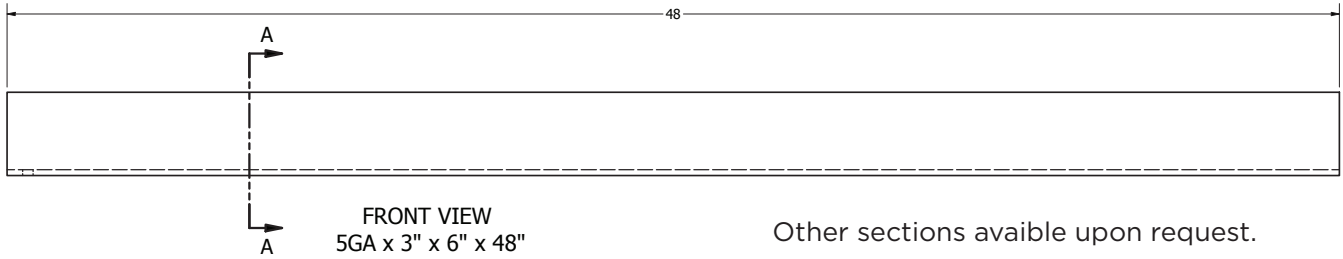
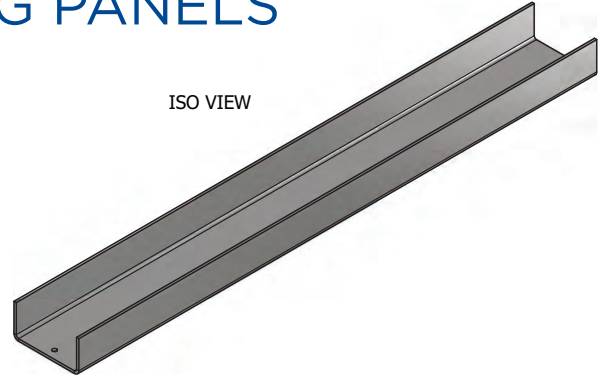

FRONT VIEW  
5GA x 3" x 6" x 48"

Other sections available upon request.

Channel Lagging Description	Cross Sectional Area (in <sup>2</sup> )	I <sub>x</sub> (in <sup>4</sup> )	I <sub>y</sub> (in <sup>4</sup> )	Grade	Tensile/Yield (ksi)	Coating (As Specified)
(3GA x 3" x 6")	2.68	14.617	2.344	A1011	29/42	Plain / A123 HDG / Epoxy
(5GA x 3" x 6")	2.364	13.054	2.086	A1011	29/42	Plain / A123 HDG / Epoxy
(7GA x 3" x 6")	2.043	11.417	1.818	A1011	29/42	Plain / A123 HDG / Epoxy
(8GA x 3" x 6")	1.880	10.569	1.680	A1011	29/42	Plain / A123 HDG / Epoxy
(10GA x 3" x 6")	1.555	8.846	1.402	A1011	29/42	Plain / A123 HDG / Epoxy
(12GA x 3" x 6")	1.219	7.021	1.109	A1011	29/42	Plain / A123 HDG / Epoxy





## JENNMAR CIVIL & SPECIALTY DIVISION

### JACOB A. HUNTER, PE - GENERAL MANAGER

jhunter@jenmar.com | Emerald Lake Dr. Matthews, NC 28104 • P: 704-893-5378 C: 740-508-2316  
Virginia Specialty: 559 Wardell Industrial Park Rd., Cedar Bluff, VA 24609 • P: 276-964-7001

### BOBBY CANNON

Western US Technical Sales  
P: 276-698-4738  
bcannon@jenmar.com

### ZACH WEST

Central US Technical Sales Engineer  
P: 512-771-7992  
zwest@jenmar.com

### PATRICK McNULTY

Eastern US Technical Sales  
P: 502-963-2404  
pmcnulty@jenmar.com

[WWW.JENMARCIVIL.COM](http://WWW.JENMARCIVIL.COM)