

JENNMAR
CIVIL

LINER PLATES

INTRODUCTION

4-flange steel liner plates, a system successfully used since 1926, provide lightweight, easy-to-handle, and safe support for soft ground. Tunneling and shaft construction are made in the USA (Sinton, TX and Louisville, KY).

4-flange liner plates manufactured by JENNMAR Civil are available in 16" and 24" widths as corrugated or smooth plates. Liner plates are formed from one piece of steel to provide longitudinal and circumferential flanges with optimum load-bearing and bending resistance characteristics.

4-flange liner plates can be galvanized, bituminous-coated, and polymer-coated (Obduro®). Grout holes and plugs can also be coated. Gasketed and tapered liner plates can also be manufactured for particular conditions. Liner plates can be installed as stand-alone structures or in conjunction with steel ribs if additional support is required.

Diameters of tunnels and shafts supported solely with 4-flange liner plates can vary from 4' to 20' (1.2 to 6.1 m).

The Liner Plate assembly distributes and transmits the load to the surrounding ground in tunnels. As a steel liner plate ring takes load vertically, it tends to deflect inward at the top and outward at the sides. Thereby, the ground resists deflection of the lining by developing a passive force equal in magnitude and opposite in direction to the force exerted by that of the lining.



DISCLAIMER: Contents of JENNMAR Civil publications are provided for informational purposes only. Nominal values for technical data are provided.

For site-specific product information, contact your JENNMAR Civil representative. While every effort has been made to ensure the accuracy of these publications, they are not to be construed as warranties or guarantees, express or implied, regarding the products or services described herein or their use or applicability. All sales are governed by JENNMAR Civil terms and conditions. We reserve the right to modify or improve the designs or specifications of such products at any time without notice. Not all products are available in all areas.



TABLE OF CONTENTS

Introduction	2
The System.....	4
Fields of Application	4
Main Advantages	4
System Components	4
System Description	4
Diagram of Load and Load Reactions	4
Specifications	5
Characteristics	10
Specifications of Liner Plates for Tunnels	11
Installation Procedure	12

THE SYSTEM

Fields of Application

- Ground support in conventional excavation
- Soft ground Tunneling
- Vertical and inclined tunnels
- TBM and MTBM jacking load resistance system
- Shaft and cofferdam support
- Smooth liner plates: shield excavation or tunnel boring machines
- Gasketed liner plates: hydrostatic conditions and reduction of water inflow
- Tapered liner plates: used for changes in alignment, both horizontal and vertical

System Description

4-flange steel liner plates provide a relatively light-weight, easy-to-handle, and safe support for soft ground tunneling because the ground that supplies the loading also supplies the respective resistance. The liner plate assembly simply distributes and transmits the load to the surrounding ground. As a steel liner plate ring takes load vertically, it tends to deflect inward at the top and outward at the sides. The ground resists deflection of the lining by developing a passive force equal in magnitude and opposite in direction to the force exerted by that of the lining. The ability of the surrounding ground to resist the outward bulge of the liner plate ring is the key to vertical load support. With the ring confined to a small amount of deflection, the thrust line induced by the load is forced

Main Advantages

- Optimized cycle times and manpower requirements
- Maximum consistent passive support strength with minimum weight of steel
- Safe support system
- Easy to store, handle, and erect
- Flexible design for different tunnel geometries and ground conditions
- Fire resistant system components
- Optional gasket plates for sealing of joints available on request
- 4-flange smooth liner plates are the only liner plate type capable of resisting tunnel boring machine jacking loads without any supplemental structural support

to follow the ring of liner plates. Thus, the ability of the assembly to withstand the applied load depends upon its ability to transmit ring thrust from plate to plate around the ring. Obviously, this ability is enhanced by the four-flange design of our systems. There are various methods for determining the required strength of tunnel linings. Nevertheless, type of ground, location and depth of cover, size and length of the tunnel, level of ground water, superimposed loading, and history always guide these calculations. Our designs conform to the latest guidance of AASHTO (American Association of State Highway and Transportation Officials) and AREMA (The American Railway Engineering and Maintenance-of-Way Association).

System Components

- Cold-formed 4-flange steel liner plates, 16["] and 24["] (406 and 610 [mm]) widths
- Thicknesses of 12, 10, 8, 7, 5, 3 gages, 5/16["], or 3/8["] available
- Corrugated or smooth plate, steel grade according to ASTM A1011
- Galvanized (ASTM A 123) and/or bituminous coated (AASHTO M190) versions available
- Customized partial plates are available to meet specific dimensions
- Liner plate gaskets and 2["] (51 [mm]) grout holes available on request
- Bolts and nuts with quick acting coarse thread according to ASTM A 307 (hot-dip galvanized: ASTM A 153)
- Obduro® polymer coating according to the aerospace standard SAE AS1003

Diagram of Load and Load Reactions

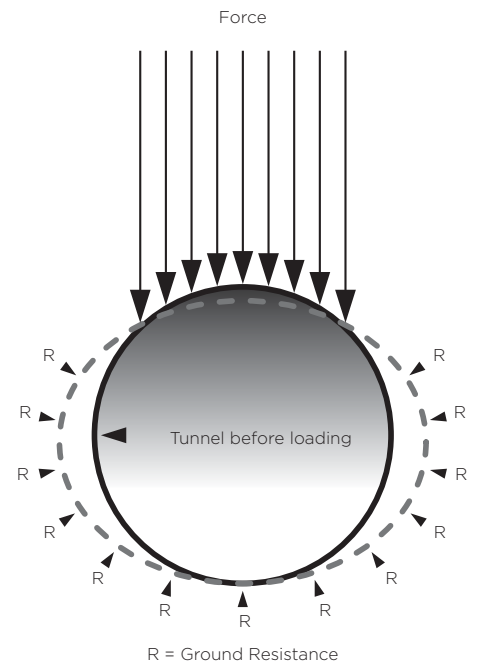

SPECIFICATIONS

Permissible Safe Loads on Circular Tunnels of Various Diameters or Arches for 16[" Wide Corrugated Liner Plates 1)

Safe Load Table (Loads Given in [psf])								
Thickness [in]	12 gage	10 gage	8 gage	7 gage	5 gage	3 gage	5/16["	3/8["
	0.1046	0.1345	0.1644	0.1793	0.2092	0.2391	0.3125	0.375
Diameter [ft]								
4	4,335	7,135	8,335	9,000	11,075	12,580	16,200	19,320
5	3,465	5,710	6,665	7,200	8,860	10,065	12,960	15,455
6	2,890	4,755	5,555	6,000	7,380	8,385	10,800	12,880
7	2,475	4,080	4,760	5,145	6,325	7,190	9,260	11,040
8	2,165	3,570	4,165	4,500	5,535	6,290	8,100	9,660
9		2,985	3,705	4,000	4,920	5,590	7,200	8,585
10		2,310	3,080	3,350	4,220	4,705	6,480	7,730
11			2,380	2,590	3,370	3,735	5,380	6,755
12				1,995	2,635	2,900	4,330	5,535
13					2,070	2,280	3,420	4,445
14					1,660	1,825	2,740	3,560
15							2,225	2,895
16							1,835	2,385
17							1,530	1,990
18								1,675
19								1,425
20								1,220

Safe Load Table (Loads Given in [kN/m²])								
Thickness [mm]	12 gage	10 gage	8 gage	7 gage	5 gage	3 gage	5/16["	3/8["
	2.66	3.42	4.18	4.55	5.31	6.07	7.94	9.53
Diameter [m]								
1.2	208	342	399	431	530	602	776	925
1.5	166	273	319	345	424	482	621	740
1.8	138	228	266	287	353	401	517	617
2.1	119	195	228	246	303	344	443	529
2.4	104	171	199	215	265	301	388	463
2.7		143	177	192	236	268	345	411
3.0		111	147	160	202	225	310	370
3.4			114	124	161	179	258	323
3.7				96	126	139	207	265
4.0					99	109	164	213
4.3					79	87	131	170
4.6							107	139
4.9							88	114
5.2							73	95
5.5								80
5.8								68
6.1								58

1) Note: 4-flange liner plates for tunnel diameters other than those shown in the tables are available. Please refer to our engineering staff for a safe load determination outline.

Sectional Properties for 16[" Wide Corrugated Liner Plates

US Customary Units												
Plate Thickness		Dimensions			Theoretical Area		Effective Area	Moment of Inertia		Radius of Gyration	Weight	
Gage	Decimal	X	Y	Side Flange							Full Plate	Half Plate
	[in]	[in]	[in]	[in]	[in²]	[in²/in]	[in²/ft]	[in⁴]	[in⁴/in]	[in]	[lbs]	[lbs]
12	0.1046	0.614	1.948	2.000	2.1268	0.1329	0.7976	0.6766	0.0423	0.56	24.2	12.9
10	0.1345	0.616	1.946	2.000	2.7184	0.1699	1.0194	0.8788	0.0549	0.57	31.2	16.5
8	0.1644	0.664	2.023	2.125	3.3442	0.2090	1.2541	1.1882	0.0743	0.60	38.2	20.6
7	0.1793	0.664	2.023	2.125	3.6368	0.2273	1.3638	1.2964	0.0810	0.60	40.9	21.7
5	0.2092	0.695	2.117	2.250	4.2182	0.2636	1.5818	1.7288	0.1081	0.64	48.6	26.2
3	0.2391	0.718	2.094	2.250	4.7924	0.2995	1.7972	1.9146	0.1197	0.63	54.9	28.9
5/16["	0.3125	0.763	2.174	2.375	6.1718	0.3857	2.3144	2.8418	0.1776	0.68	68.6	36.1
3/8["	0.3750	0.913	2.149	2.500	7.3598	0.4600	2.7600	3.7020	0.2314	0.71	82.3	43.3

SI Units												
Plate Thickness		Dimensions			Theoretical Area		Effective Area	Moment of Inertia		Radius of Gyration	Weight	
Gage	Decimal	X	Y	Side Flange							Full Plate	Half Plate
	[mm]	[mm]	[mm]	[mm]	[mm²]	[mm²/mm]	[mm²/mm]	[mm⁴]	[mm⁴/mm]	[mm]	[kg]	[kg]
12	2.657	15.60	49.48	50.80	1372.13	3.38	1.73	2,816,166	693.2	14.22	11.0	5.9
10	3.416	15.65	49.43	50.80	1753.80	4.32	2.21	3,657,769	899.6	14.48	14.2	7.5
8	4.176	16.87	51.38	53.98	2157.54	5.31	2.72	4,945,563	1217.6	15.24	17.3	9.3
7	4.554	16.87	51.38	53.98	2346.32	5.77	2.95	5,395,917	1327.4	15.24	18.6	9.8
5	5.314	17.65	53.77	57.15	2721.41	6.70	3.43	7,195,666	1771.4	16.26	22.0	11.9
3	6.073	18.24	53.19	57.15	3091.86	7.61	3.89	7,969,008	1961.5	16.00	24.9	13.1
5/16["	7.938	19.38	55.22	60.33	3981.80	9.80	5.01	11,828,229	2910.3	17.27	31.1	16.4
3/8["	9.525	23.19	54.58	63.50	4748.25	11.68	5.98	15,408,581	3792.0	18.03	37.3	19.6

Permissible Safe Loads on Circular Tunnels of Various Diameters or Arches for 16[" Wide Smooth Liner Plates¹⁾

Safe Load Table (Loads Given in [psf])								
Thickness [in]	12 gage	10 gage	8 gage	7 gage	5 gage	3 gage	5/16["	3/8["
	0.1046	0.1345	0.1644	0.1793	0.2092	0.2391	0.3125	0.375
Diameter [ft]								
4	4,335	6,870	8,335	9,000	10,800	12,265	15,995	19,195
5	3,465	5,495	6,665	7,200	8,640	9,815	12,795	15,355
6	2,890	4,580	5,555	6,000	7,200	8,175	10,665	12,795
7	-	3,850	4,760	5,145	6,170	7,010	9,140	10,970
8	-	-	3,915	4,255	5,340	6,065	8,000	9,600
9	-	-	2,905	3,160	4,095	4,650	6,545	8,490
10	-	-	-	-	3,045	3,455	5,020	6,735
11	-	-	-	-	2,285	2,595	3,780	5,210
12	-	-	-	-	-	2,000	2,910	4,010
13	-	-	-	-	-	-	2,290	3,155
14	-	-	-	-	-	-	1,835	2,525
15	-	-	-	-	-	-	-	2,055
16	-	-	-	-	-	-	-	1,690
17	-	-	-	-	-	-	-	1,410
18	-	-	-	-	-	-	-	-
19	-	-	-	-	-	-	-	-
20	-	-	-	-	-	-	-	-

Safe Load Table (Loads Given in [kN/m ²])								
Thickness [mm]	12 gage	10 gage	8 gage	7 gage	5 gage	3 gage	5/16["	3/8["
	2.66	3.42	4.18	4.55	5.31	6.07	7.94	9.53
Diameter [m]								
1.2	208	329	399	431	517	587	766	919
1.5	166	263	319	345	414	470	613	735
1.8	138	219	266	287	345	391	511	613
2.1	-	184	228	246	295	336	438	525
2.4	-	-	187	204	256	290	383	460
2.7	-	-	139	151	196	223	313	407
3.0	-	-	-	-	146	165	240	322
3.4	-	-	-	-	109	124	181	249
3.7	-	-	-	-	-	96	139	192
4.0	-	-	-	-	-	-	110	151
4.3	-	-	-	-	-	-	88	121
4.6	-	-	-	-	-	-	-	98
4.9	-	-	-	-	-	-	-	81
5.2	-	-	-	-	-	-	-	68
5.5	-	-	-	-	-	-	-	-
5.8	-	-	-	-	-	-	-	-
6.1	-	-	-	-	-	-	-	-

1) Note: 4-flange liner plates for tunnel diameters other than those shown in the tables are available. Please refer to our engineering staff for a safe load determination outline.

Sectional Properties for 16[" Wide Smooth Liner Plates

US Customary Units												
Plate Thickness		Dimensions			Theoretical Area		Effective Area	Moment of Inertia		Radius of Gyration	Weight	
Gage	Decimal	X	Y	Side Flange							Full Plate	Half Plate
	[in]	[in]	[in]	[in]	[in ²]	[in ² /in]	[in ² /ft]	[in ⁴]	[in ⁴ /in]	[in]	[lbs]	[lbs]
12	0.1046	0.246	1.754	2	2.0482	0.1280	0.7681	0.3386	0.0212	0.46	24.2	12.9
10	0.1345	0.260	1.740	2	2.6176	0.1636	0.9816	0.5544	0.0346	0.46	31.2	16.5
8	0.1644	0.295	1.830	2.125	3.2209	0.2013	1.2078	0.7944	0.0497	0.50	38.2	20.6
7	0.1793	0.301	1.824	2.125	3.5025	0.2189	1.3134	0.8583	0.0536	0.50	40.9	21.7
5	0.2092	0.338	1.912	2.250	4.1136	0.2571	1.5426	1.1647	0.0728	0.53	48.6	26.2
3	0.2391	0.351	1.899	2.250	4.6729	0.2921	1.7523	1.3083	0.0818	0.53	54.9	28.9
5/16["	0.3125	0.408	1.967	2.375	6.0938	0.3809	2.2852	1.9294	0.1206	0.56	68.6	36.1
3/8["	0.3750	0.460	2.040	2.500	7.3126	0.4570	2.7422	2.6142	0.1634	0.60	82.3	43.3

SI Units												
Plate Thickness		Dimensions			Theoretical Area		Effective Area	Moment of Inertia		Radius of Gyration	Weight	
Gage	Decimal	X	Y	Side Flange							Full Plate	Half Plate
	[mm]	[mm]	[mm]	[mm]	[mm ²]	[mm ² /mm]	[mm ² /mm]	[mm ⁴]	[mm ⁴ /mm]	[mm]	[kg]	[kg]
12	2.657	6.25	44.55	50.80	1,321.42	3.25	1.66	140,936	347.4	11.68	11.0	5.9
10	3.416	6.60	44.20	50.80	1,688.77	4.16	2.13	230,759	567.0	11.68	14.2	7.5
8	4.176	7.49	46.48	53.98	2,078.00	5.11	2.62	330,654	814.4	12.70	17.3	9.3
7	4.554	7.65	46.33	53.98	2,259.67	5.56	2.85	357,251	878.3	12.70	18.6	9.8
5	5.314	8.59	48.56	57.15	2,653.93	6.53	3.34	484,785	1,193.0	13.46	22.0	11.9
3	6.073	8.92	48.23	57.15	3,014.77	7.42	3.80	544,556	1,340.5	13.46	24.9	13.1
5/16["	7.938	10.36	49.96	60.33	3,931.48	9.67	4.95	803,077	1,976.3	14.22	31.1	16.4
3/8["	9.525	11.68	51.82	63.50	4,717.80	11.61	5.94	1,088,112	2,677.6	15.24	37.3	19.6

Permissible Safe Loads on Circular Tunnels of Various Diameters or Arches for 24[“] Wide Corrugated Liner Plates¹⁾

Safe Load Table (Loads Given in [psf])								
Thickness [in]	12 gage	10 gage	8 gage	7 gage	5 gage	3 gage	5/16[“]	3/8[“]
	0.1046	0.1345	0.1644	0.1793	0.2092	0.2391	0.3125	0.375
Diameter [ft]								
4 ²⁾	4,335	6,570	8,045	8,750	10,230	11,615	15,075	18,000
5	3,465	5,255	6,440	7,000	8,185	9,295	12,060	14,400
6	2,890	4,380	5,365	5,830	6,820	7,745	10,050	12,000
7	2,475	3,755	4,600	5,000	5,845	6,640	8,615	10,285
8	-	3,115	4,025	4,375	5,115	5,810	7,535	9,000
9	-	-	3,215	3,410	4,365	4,955	6,700	8,000
10	-	-	2,440	2,560	3,410	3,870	5,410	6,855
11	-	-	-	-	2,595	2,945	4,225	5,480
12	-	-	-	-	2,000	2,270	3,255	4,280
13	-	-	-	-	-	-	2,560	3,365
14	-	-	-	-	-	-	2,050	2,695
15	-	-	-	-	-	-	1,665	2,190
16	-	-	-	-	-	-	-	1,805
17	-	-	-	-	-	-	-	1,505
18	-	-	-	-	-	-	-	-
19	-	-	-	-	-	-	-	-
20	-	-	-	-	-	-	-	-

Safe Load Table (Loads Given in [kN/m ²])								
Thickness [mm]	12 gage	10 gage	8 gage	7 gage	5 gage	3 gage	5/16[“]	3/8[“]
	2.66	3.42	4.18	4.55	5.31	6.07	7.94	9.53
Diameter [m]								
1.2 2)	208	315	385	419	490	556	722	862
1.5	166	252	308	335	392	445	577	689
1.8	138	210	257	279	327	371	481	575
2.1	119	180	220	239	280	318	412	492
2.4	-	149	193	209	245	278	361	431
2.7	-	-	154	163	209	237	321	383
3.0	-	-	117	123	163	185	259	328
3.4	-	-	-	-	124	141	202	262
3.7	-	-	-	-	96	109	156	205
4.0	-	-	-	-	-	-	123	161
4.3	-	-	-	-	-	-	98	129
4.6	-	-	-	-	-	-	80	105
4.9	-	-	-	-	-	-	-	86
5.2	-	-	-	-	-	-	-	72
5.5	-	-	-	-	-	-	-	-
5.8	-	-	-	-	-	-	-	-
6.1	-	-	-	-	-	-	-	-

1) Note: 4-flange liner plates for tunnel diameters other than those shown in the tables are available.

Please refer to our engineering staff for a safe load determination outline.

2) Not recommended for circular tunnel applications.

Sectional Properties for 24[“] Wide Corrugated Liner Plates

US Customary Units												
Plate Thickness		Dimensions			Theoretical Area		Effective Area	Moment of Inertia		Radius of Gyration	Weight	
Gage	Decimal	X	Y	Side Flange							Full Plate	Half Plate
	[in]	[in]	[in]	[in]	[in ²]	[in ² /in]	[in ² /ft]	[in ⁴]	[in ⁴ /in]	[in]	[lbs]	[lbs]
12	0.1046	0.584	2.041	2	2.9379	0.1224	0.7345	0.7832	0.0326	0.52	34.5	18.7
10	0.1345	0.597	2.028	2	3.7532	0.1564	0.9383	0.9910	0.0413	0.51	44.2	23.6
8	0.1644	0.628	2.122	2.125	4.5984	0.1916	1.1496	1.3683	0.0570	0.55	52.8	28.4
7	0.1793	0.635	2.115	2.125	4.9990	0.2083	1.2498	1.4814	0.0617	0.54	56.9	30.7
5	0.2092	0.667	2.208	2.250	5.8468	0.2436	1.4617	1.9463	0.0811	0.58	68.5	37.0
3	0.2391	0.680	2.195	2.250	6.6383	0.2766	1.6596	2.1933	0.0914	0.58	80.2	43.2
5/16[“]	0.3125	0.731	2.269	2.375	8.6130	0.3589	2.1533	3.1563	0.1315	0.61	101.6	54.0
3/8[“]	0.3750	0.779	2.346	2.50	10.2846	0.4285	2.5712	4.1816	0.1742	0.64	121.9	65.8

SI Units												
Plate Thickness		Dimensions			Theoretical Area		Effective Area	Moment of Inertia		Radius of Gyration	Weight	
Gage	Decimal	X	Y	Side Flange							Full Plate	Half Plate
	[mm]	[mm]	[mm]	[mm]	[mm ²]	[mm ² /mm]	[mm ² /mm]	[mm ⁴]	[mm ⁴ /mm]	[mm]	[kg]	[kg]
12	2.657	14.83	51.84	50.80	1,895.42	3.11	1.59	325,992	534.2	13.21	15.6	8.5
10	3.416	15.16	51.51	50.80	2,421.41	3.97	2.03	412,485	676.8	12.95	20.0	10.7
8	4.176	15.95	53.90	53.98	2,966.70	4.87	2.49	569,529	934.1	13.97	23.9	12.9
7	4.554	16.13	53.72	53.98	3,225.15	5.29	2.71	616,605	1011.1	13.72	25.8	13.9
5	5.314	16.94	56.08	57.15	3,772.12	6.19	3.17	810,111	1329.0	14.73	31.1	16.8
3	6.073	17.27	55.75	57.15	4,282.77	7.03	3.60	912,920	1497.8	14.73	36.4	19.6
5/16[“]	7.938	18.57	57.63	60.33	5,556.76	9.12	4.67	1,313,751	2154.9	15.49	46.1	24.5
3/8[“]	9.525	19.79	59.59	63.50	6,635.21	10.88	5.57	1,740,513	2854.6	16.26	55.3	29.8

Permissible Safe Loads on Circular Tunnels of Various Diameters or Arches for 24["] Wide Smooth Liner Plates¹⁾

Safe Load Table (Loads Given in [psf])								
Thickness [in]	12 gage	10 gage	8 gage	7 gage	5 gage	3 gage	5/16["]	3/8["]
	0.1046	0.1345	0.1644	0.1793	0.2092	0.2391	0.3125	0.375
Diameter [ft]								
4 ²⁾	4,335	6,465	7,940	8,640	10,130	11,525	15,040	18,050
5	3,465	5,170	6,350	6,910	8,100	9,220	12,030	14,440
6	-	4,290	5,290	5,760	6,750	7,685	10,025	12,030
7	-	-	4,110	4,470	5,675	6,460	8,595	10,315
8	-	-	-	3,130	4,160	4,735	6,785	8,745
9	-	-	-	-	2,950	3,355	4,970	6,640
10	-	-	-	-	-	2,445	3,620	4,895
11	-	-	-	-	-	-	2,720	3,680
12	-	-	-	-	-	-	2,095	2,835
13	-	-	-	-	-	-	-	2,230
14	-	-	-	-	-	-	-	1,785
15	-	-	-	-	-	-	-	-
16	-	-	-	-	-	-	-	-
17	-	-	-	-	-	-	-	-
18	-	-	-	-	-	-	-	-
19	-	-	-	-	-	-	-	-
20	-	-	-	-	-	-	-	-

Safe Load Table (Loads Given in [kN/m ²])								
Thickness [mm]	12 gage	10 gage	8 gage	7 gage	5 gage	3 gage	5/16["]	3/8["]
	2.66	3.42	4.18	4.55	5.31	6.07	7.94	9.53
Diameter [m]								
1.2 ²⁾	208	310	380	414	485	552	720	864
1.5	166	248	304	331	388	441	576	691
1.8	-	205	253	276	323	368	480	576
2.1	-	-	197	214	272	309	412	494
2.4	-	-	-	150	199	227	325	420
2.7	-	-	-	-	141	161	238	319
3.0	-	-	-	-	-	117	173	236
3.4	-	-	-	-	-	-	130	177
3.7	-	-	-	-	-	-	100	136
4.0	-	-	-	-	-	-	-	107
4.3	-	-	-	-	-	-	-	86
4.6	-	-	-	-	-	-	-	-
4.9	-	-	-	-	-	-	-	-
5.2	-	-	-	-	-	-	-	-
5.5	-	-	-	-	-	-	-	-
5.8	-	-	-	-	-	-	-	-
6.1	-	-	-	-	-	-	-	-

1) Note: 4-flange liner plates for tunnel diameters other than those shown in the tables are available.

Please refer to our engineering staff for a safe load determination outline.

2) Not recommended for circular tunnel applications.

Sectional Properties for 24["] Wide Smooth Liner Plates

US Customary Units													
Plate Thickness		Dimensions			Theoretical Area		Effective Area	Moment of Inertia		Radius of Gyration	Weight		
Gage	Decimal	X	Y	Side Flange							Full Plate	Half Plate	
	[in]	[in]	[in]	[in]	[in ²]	[in ² /in]	[in ² /ft]	[in ⁴]	[in ⁴ /in]	[in]	[lbs]	[lbs]	
12	0.1046	0.190	1.810	2	2.8850	0.1202	0.7210	0.4630	0.0193	0.40	34.5	18.7	
10	0.1345	0.203	1.767	2	3.6940	0.1539	0.9235	0.5840	0.0243	0.40	44.2	23.6	
8	0.1644	0.233	1.892	2.125	4.5360	0.1890	1.1340	0.8400	0.0350	0.43	52.8	28.4	
7	0.1793	0.240	1.885	2.125	4.9370	0.2057	1.2343	0.9080	0.0378	0.43	56.9	30.7	
5	0.2092	0.271	1.979	2.25	5.7870	0.2411	1.4468	1.2360	0.0515	0.46	68.5	37.0	
3	0.2391	0.284	1.966	2.25	6.5860	0.2744	1.6465	1.3900	0.0579	0.46	80.2	43.2	
5/16["]	0.3125	0.334	2.041	2.375	8.5940	0.3581	2.1485	2.0610	0.0859	0.49	101.6	54.0	
3/8["]	0.3750	0.381	2.119	2.5	10.3130	0.4297	2.5783	2.8070	0.1170	0.52	121.9	65.8	

SI Units													
Plate Thickness		Dimensions			Theoretical Area		Effective Area	Moment of Inertia		Radius of Gyration	Weight		
Gage	Decimal	X	Y	Side Flange							Full Plate	Half Plate	
	[mm]	[mm]	[mm]	[mm]	[mm ²]	[mm ² /mm]	[mm ² /mm]	[mm ⁴]	[mm ⁴ /mm]	[mm]	[kg]	[kg]	
12	2.657	4.83	45.97	50.80	1861.29	3.05	1.56	192,715	316.3	10.16	15.6	8.5	
10	3.416	5.16	44.88	50.80	2383.22	3.91	2.00	243,079	398.2	10.16	20.0	10.7	
8	4.176	5.92	48.06	53.98	2926.45	4.80	2.46	349,634	573.5	10.92	23.9	12.9	
7	4.554	6.10	47.88	53.98	3185.15	5.22	2.67	377,938	619.4	10.92	25.8	13.9	
5	5.314	6.88	50.27	57.15	3733.54	6.12	3.13	514,462	843.9	11.68	31.1	16.8	
3	6.073	7.21	49.94	57.15	4249.02	6.97	3.57	578,562	948.8	11.68	36.4	19.6	
5/16["]	7.938	8.48	51.84	60.33	5544.51	9.10	4.66	857,853	1407.6	12.45	46.1	24.5	
3/8["]	9.525	9.68	53.82	63.50	6653.54	10.91	5.59	1,168,362	1917.3	13.21	55.3	29.8	

Allowable Jacking Loads on Circular Tunnels of Various Diameters for 16[" Wide Smooth Liner Plates¹⁾

Allowable Load Given in Short Tons (2000 [lbs])							Allowable Load [kN]						
Thickness [in]	8 gage	7 gage	5 gage	3 gage	5/16["	3/8["	Thickness [mm]	8 gage	7 gage	5 gage	3 gage	5/16["	3/8["
	0.1644	0.1793	0.2092	0.2391	0.3125	0.375		4.18	4.55	5.31	6.07	7.94	9.53
Diameter [ft]							Diameter [m]						
4	50	59	83	109	192	298	1.2	445	525	738	970	1,708	2,651
5	63	74	103	136	240	372	1.5	560	658	916	1,210	2,135	3,309
6	76	89	124	163	288	447	1.8	676	792	1,103	1,450	2,562	3,977
7	88	104	145	190	336	521	2.1	783	925	1,290	1,690	2,989	4,635
8	101	119	165	217	384	596	2.4	898	1,059	1,468	1,930	3,416	5,302
9	114	134	186	245	432	670	2.7	1,014	1,192	1,655	2,180	3,843	5,960
10	-	-	207	272	480	745	3.0	-	-	1,841	2,420	4,270	6,628
11	-	-	227	299	528	819	3.4	-	-	2,019	2,660	4,697	7,286
12	-	-	-	326	576	894	3.7	-	-	-	2,900	5,124	7,953
13	-	-	-	-	624	968	4.0	-	-	-	-	5,551	8,611
14	-	-	-	-	672	1,043	4.3	-	-	-	-	5,978	9,279
15	-	-	-	-	-	1,117	4.6	-	-	-	-	-	9,937
16	-	-	-	-	-	1,192	4.9	-	-	-	-	-	10,604
17	-	-	-	-	-	1,266	5.2	-	-	-	-	-	11,262

Allowable Jacking Loads on Circular Tunnels of Various Diameters for 24[" Wide Smooth Liner Plates¹⁾

Allowable Load Given in Short Tons (2000 [lbs])							Allowable Load [kN]						
Thickness [in]	8 gage	7 gage	5 gage	3 gage	5/16["	3/8["	Thickness [mm]	8 gage	7 gage	5 gage	3 gage	5/16["	3/8["
	0.1644	0.1793	0.2092	0.2391	0.3125	0.375		4.18	4.55	5.31	6.07	7.94	9.53
Diameter [ft]							Diameter [m]						
4	40	47	63	80	131	196	1.2	356	418	560	712	1,165	1,744
5	51	58	79	100	164	245	1.5	454	516	703	890	1,459	2,180
6	61	70	95	120	197	294	1.8	543	623	845	1,068	1,753	2,615
7	71	82	110	140	229	342	2.1	632	729	979	1,245	2,037	3,042
8	81	93	126	160	262	391	2.4	721	827	1,121	1,423	2,331	3,478
9	-	-	142	180	295	440	2.7	-	-	1,263	1,601	2,624	3,914
10	-	-	-	200	328	489	3.0	-	-	-	1,779	2,918	4,350
11	-	-	-	-	360	538	3.4	-	-	-	-	3,203	4,786
12	-	-	-	-	393	587	3.7	-	-	-	-	3,496	5,222
13	-	-	-	-	-	636	4.0	-	-	-	-	-	5,658
14	-	-	-	-	-	685	4.3	-	-	-	-	-	6,094
15	-	-	-	-	-	-	4.6	-	-	-	-	-	-
16	-	-	-	-	-	-	4.9	-	-	-	-	-	-
17	-	-	-	-	-	-	5.2	-	-	-	-	-	-

1) Note: 4-flange liner plates for tunnel diameters other than those shown in the tables are available. Please refer to our engineering staff for a safe load determination outline.



CHARACTERISTICS

Advantages of 4-flange Tunneling Liner Plates over conventional 2-flange Liner Plates

- All 4-flange liner plates are similar in size and shape, e.g. 2-flange plates vary considerably in length
- 4-flange liner plates are erected from inside the tunnel, whereas 2-flange plates require reaching behind the plates to install bolts and nuts
- Storage, manipulation, and erection of 4-flange liner plates requires less time and manpower
- 4-flange liner plates are the only liner plate system form which can be used to push off the liner plate flange with a TBM, MTBM, or shield without supplemental structural reinforcement
- Less excavation because 4-flange plates are only 2 to 2 ½ [in] deep while the deeply corrugated two-flange plates can be 4 to 5 [in] deep
- Less grout is used behind 4-flange plates because of the shallower corrugations versus the deeper 2-flange plates
- 4-flange liner plates are measured to the outside of plate while 2-flange plates are measured to the net neutral axis (NNA)

Liner Plate Support Types

- Liner Plates only
- Ribs inside Liner Plates
- Liner Plates between ribs

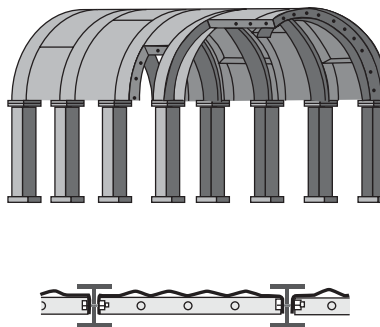
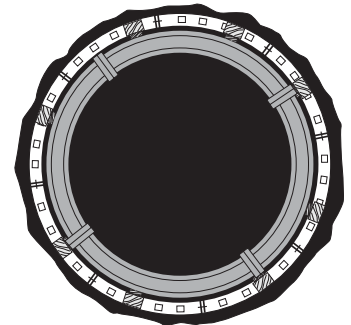
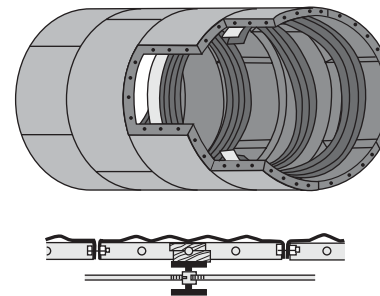
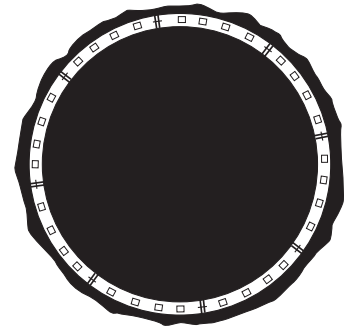
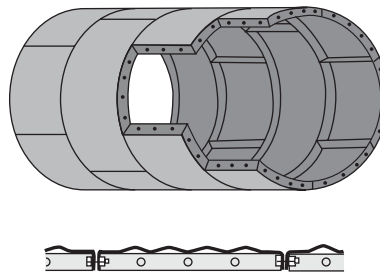

SPECIFICATIONS OF LINER PLATES FOR TUNNELS

Minimum Stiffness Requirements

Let's discuss the effective stiffness of 2-flange tunnel Liner Plates. When you're competing against a product that works as well as and installs as easily as our 4-flange Liner Plates one of the few things you can do to compete is create confusion. That's what we want to clear up once and for all.

Stiffness is a property that becomes a factor in cut and fill culvert work. It's much less of a factor in tunneling where you're mining through undisturbed earth. The confusion seems to be caused by the minimum stiffness

requirements as published by AASHTO (American Association of State Highway and Transportation Officials) and AREMA (American Railway Engineering and Maintenance-of-Way Association). These specifications call for a minimum stiffness of 50 for 2-flange plates and 111 for 4-flange plates.

Now, right off, that sounds as if the 2-flange structure is over twice as stiff as the 4-flange. Our 4-flange Liner Plate provides an actual stiffness very close to and in some cases greater than that provided by the 2-flange plate.



Safety Factors

Both AASHTO and AREMA specifications state that the stiffness shown for 2- and 4-flange plates are the recommended minimums and that actual conditions may require higher values. However, specifying higher values should be based on "...intimate knowledge of the project and practical experience". Unfortunately, the field of tunnel design and engineering is so limited that many of today's engineers have had little opportunity for practical experience.

Over designing, to be on the safe side is common practice. But, specifying a safety factor of 2 or 3 on the stiffness requirement implies that the designer is unfamiliar with liner plate tunneling. Sound engineering specifications must be based on good judgment and intimate knowledge of the project, not on inflated minimum stiffness values.

The design calculations for either type of liner plate are based on the assumption that the lining is flexible. And, by being flexible, it can interact with the surrounding ground in order to carry the load primarily as ring thrust.

The necessary design parameters for these flexible tunnel linings are: moment of inertia (I), radius of gyration (r) and effective area (A). In addition, minimum values of yield, tensile and ultimate seam strength are normally specified.

Nowhere in the design calculations will one find the section modulus (S) property utilized. Therefore, it can be safely assumed that it has no bearing on the ability of either 2- or 4-flange Liner Plates to support ground loads through flexure. To clearly emphasize the parameters necessary for Liner Plate design, we have included a set of calculations for a typical 90["] diameter, 2-flange, 10 gage Liner Plate tunnel as per AREMA specifications.

INSTALLATION PROCEDURE

Introduction

Tunnels excavated by full face, heading and bench, or multiple drift procedures are considered conventional methods. Liner plates used with any construction method utilizing a full or partial shield, a tunneling machine, or other equipment which will exert a force upon the Liner Plates to propel, steer, or stabilize the equipment are considered special cases and are not covered by these specifications. In any case, Liner Plates must be assembled in accordance with the manufacturer's instructions.

Assembly

4-flange Liner Plates and all accessories required for erection must be transported to the point of installation in advance. Preferably, the unsupported section (span) in the excavation area is always kept at a minimum, and complete liner plate rings are assembled at once. Full-face connection of 4-flange Liner Plates is accomplished using original bolts and nuts with quick acting coarse thread. Bolts should be "snug tight" as defined by AISC (American Institute of Steel Construction).

Grouting

It is assumed that grouting is always performed to transfer ground loads to the 4-flange Liner Plates. Grout holes with plugs shall be provided at a spacing sufficient to allow filling of all voids with grouting material. Grouting or backfilling should start at the lowest grout hole and proceed upward, preferably filling both sides of the tunnel simultaneously. The frequency of grouting depends on ground conditions, tunnel diameter, and total length.

Further References

- AASHTO Standard Specification for Highway Bridges, Division I, Section 16
- AREMA Manual for Railway Engineering, Section 4
- Our recommendations for the determination of loading on tunnel Liner Plates



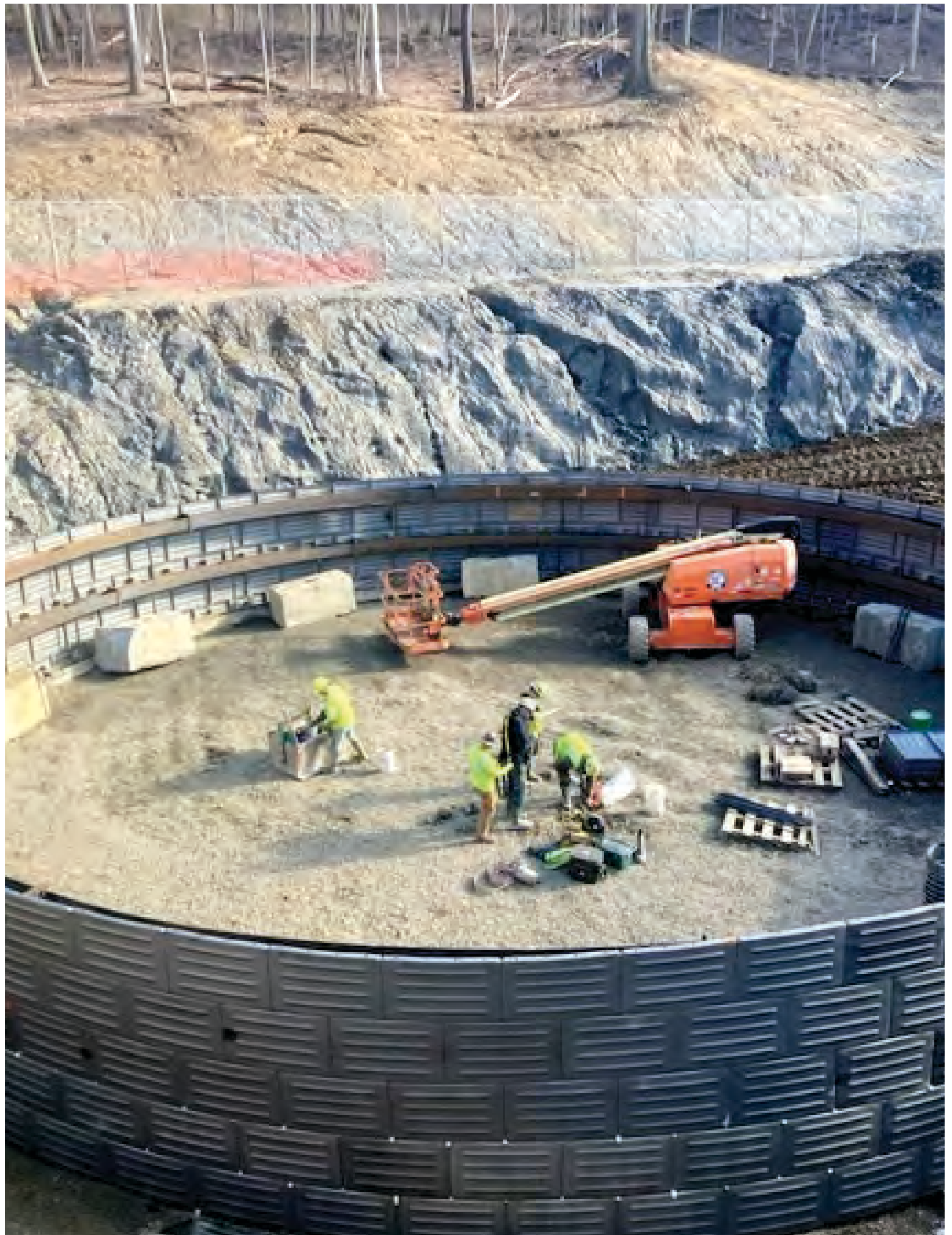

NOTES:

NOTES:



JENNMAR CIVIL & SPECIALTY DIVISION

JACOB A. HUNTER, PE - GENERAL MANAGER

jhunter@jennmar.com | Emerald Lake Dr. Matthews, NC 28104 • P: 704-893-5378 C: 740-508-2316
Virginia Specialty: 559 Wardell Industrial Park Rd., Cedar Bluff, VA 24609 • P: 276-964-7001

BOBBY CANNON

Western US Technical Sales
P: 276-698-4738
bcannon@jennmar.com

ZACH WEST

Central US Technical Sales Engineer
P: 512-771-7992
zwest@jennmar.com

PATRICK McNULTY

Eastern US Technical Sales
P: 502-963-2404
pmcnulty@jennmar.com

WWW.JENNMARCIVIL.COM